



Exceptional service in the national interest

LATENCY AND BANDWIDTH MICROBENCHMARKS OF SIX US DEPARTMENT OF ENERGY SYSTEMS IN THE TOP500

Carl Pearson, Christopher M. Siefert, Stephen L. Olivier, Andrey Prokopenko¹, Timothy J. Fuller, Jonathan Hu

Sandia National Laboratories, ¹Oak Ridge National Laboratory

Tue Nov 2, 2023

Poster Lightning Talks, Cluster 2023

INTRO

MPI latency, CPU/accelerator memory bandwidth, accelerator copy latency, and accelerator control latency benchmark results from six archetypal systems in the June 2023 Top500 [1] list

BabelStream [2]

- CPU memory bandwidth
- GPU memory bandwidth

OSU MPI Microbenchmarks [3]

- CPU/CPU MPI Latency
- GPU/GPU MPI Latency

Comm | Scope [4]

- GPU control latencies
- CPU/GPU copy bandwidth
- GPU/GPU copy bandwidth

- Many applications are becoming performance-portable
- Acceptance testing results are not generally public
- Existing benchmark publications compare few systems
- Ad-hoc measurements fragmented through literature

Upcoming paper in
PMBS'23 (SC workshop)
More systems
More benchmarks
More discussion

[1] TOP500 June 2023. [Online]. Available: <https://www.top500.org/lists/top500/2023/06/>

[2] T. Deakin, J. Price, M. Martineau, and S. McIntosh-Smith, "Evaluating attainable memory bandwidth of parallel programming models via BabelStream," International Journal of Computational Science and Engineering, vol. 17, no. 3, pp. 247–262, 2018.

[3] OSU micro-benchmarks. [Online]. Available: <http://mvapich.cse.ohio-state.edu/benchmarks/>

[4] C. Pearson, A. Dakkak, S. Hashash, C. Li, I.-H. Chung, J. Xiong, and W.-M. Hwu, "Evaluating characteristics of CUDA communication primitives on high-bandwidth interconnects," in Proceedings of the 2019 ACM/SPEC International Conference on Performance Engineering, 2019, pp. 209–218



SYSTEMS

System Name	Top500 Rank	Loc.	CPU	Accelerator	CPU Compiler	GPU Compiler	MPI
Frontier	1	ORNL	AMD Zen 3	AMD MI250X	hipcc 5.3.0		cray-mpich/8.1.23
Summit	5	ORNL	IBM POWER9	NVIDIA V100	xl/16.1.1-10	nvcc 11.0.3	spectrum-mpi/10.4.0.3-20210112
Perlmutter ¹	8	NERSC	AMD Zen 3	NVIDIA A100	gcc/11.2.0	nvcc 11.7.64	cray-mpich/8.1.25
Trinity	29	LANL	Intel KNL	--	intel/2021.5.0	--	cray-mpich/7.7.20
Sawtooth	109	INL	Intel Cascade Lake	--	intel/19.0.5	--	intel-mpi/2019.0.117
Eagle	127	NREL	Intel Skylake	--	gcc/8.4.0	--	openmpi/4.1.0

Table 1: Summary of representative DOE systems in the June 2023 Top500. ¹PrgEnv-gnu.

- Variety of CPUs and GPUS of interest to the U.S. DOE
- Maintain system defaults wherever possible
 - modules, compilers, drivers, etc...
- Mean & standard deviation of 100 samples

STREAM COPY BANDWIDTH

dual-socket CPUs



System Name	CPU	GPU
Frontier	111.97 ± 0.24	1,368.69 ± 0.11
Summit	237.42 ± 0.24	805.30 ± 0.11
Perlmutter	112.91 ± 0.26	1,396.47 ± 0.24
Trinity	256.64 ± 2.11	N/A
Sawtooth	238.70 ± 8.39	N/A
Eagle	208.24 ± 0.92	N/A

Table 2: BabelStream COPY bandwidths (GB/s).



MPI LATENCY

System Name	On-Socket (μs)		GPU \rightarrow GPU (μs)	
	Socket	Node	Socket	Node
Frontier	0.45 ± 0.01	N/A	N/A	0.43 ± 0.00
Summit	0.35 ± 0.08	0.86 ± 0.00	18.2 ± 0.22^2	19.40 ± 0.20
Perlmutter	0.46 ± 0.06	1.11 ± 0.04	N/A	13.50 ± 0.13
Trinity	0.67 ± 0.01	0.99 ± 0.01	N/A	N/A
Sawtooth	0.48 ± 0.01^1		N/A	N/A
Eagle	0.17 ± 0.00	0.38 ± 0.01	N/A	N/A

Table 3: MPI latencies. Column subheadings indicate the communication domain. ¹ These two measurements are the same. ² Refers to GPUs attached to the same POWER9 CPU.

CPU/GPU TRANSFER BANDWIDTHS

System Name	Host/GPU (GB/s)		GPU/GPU (GB/s)		
	A	B	A	B	C,D
Frontier	26.70 ± 0.00	N/A	50.90 ± 0.00	50.95 ± 0.00	36.95 ± 0.00
Summit	47.91 ± 0.00	37.61 ± 0.03	34.17 ± 0.01	30.29 ± 0.21	N/A
Perlmutter	26.50 ± 0.00	N/A	19.30 ± 0.05	N/A	N/A

Table 4: Intranode transfer bandwidths (GB/s). Host/GPU is mean of host-to-device and device-to-host

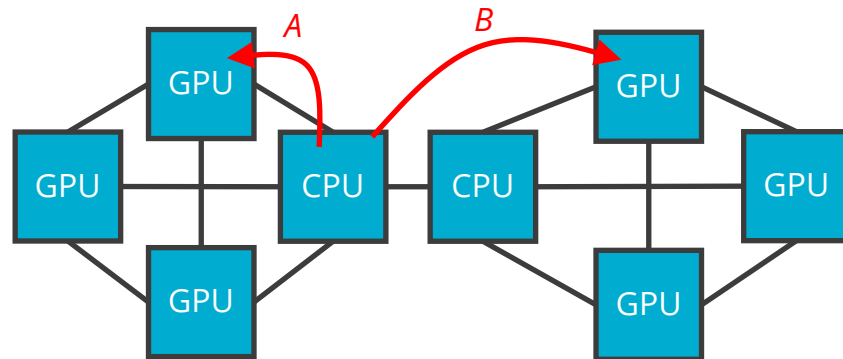

Fig. 2: Summit node showing transfer kinds (Tab. 3).

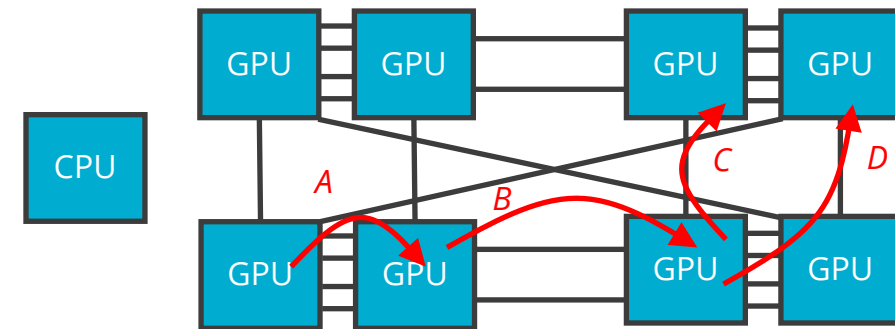

Fig. 3: Frontier node showing transfer kinds (Tabs. 3, 4).

GPU CONTROL AND TRANSFER LATENCIES

System Name	Kernel (μs)	Sync (μs)	Host/GPU (μs)	GPU \rightarrow GPU (μs)			
				A	B	C	D
Frontier	1.50 ± 0.00	0.14 ± 0.00	13.03 ± 0.05	12.02 ± 0.05	12.56 ± 0.03	12.68 ± 0.02	12.02 ± 0.10
Summit	4.7 ± 0.00	4.54 ± 0.00	7.70 ± 0.03	24.97 ± 0.15	27.44 ± 0.14	N/A	N/A
Perlmutter	1.77 ± 0.01	4.24 ± 0.01	4.24 ± 0.01	14.74 ± 0.41	N/A	N/A	N/A

Table 5: GPU control and transfer latencies.

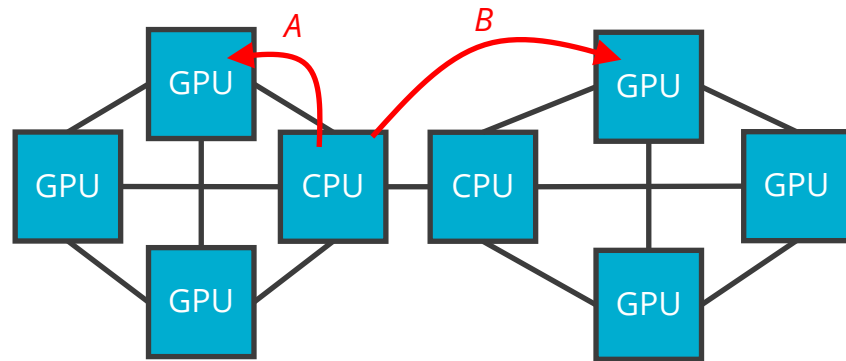

Fig. 2: Summit node showing transfer kinds (Tab. 3).

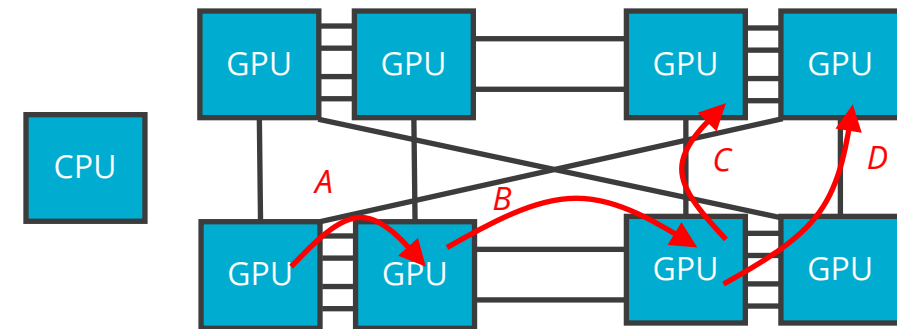

Fig. 3: Frontier node showing transfer kinds (Tabs. 3, 4).



THANK YOU